



12/93 Lyons Road Drummoyne, NSW



2



1



1

SOLD Prior to AUCTION - The Perfect Start

Nestled at the back of the building, this beautifully presented apartment enjoys minimal common walls, light filled rooms, modern kitchen and sunny balcony with district views and water glimpses. Built-in wardrobes in both bedrooms, internal laundry and your own car space only further enhances the appeal of this top floor apartment. Offering exceptional convenience with local shops, cafes, transport, parks and bay only moments away, making this apartment just perfect for the first home buyer or investor.

- Light filled top floor 2 bedroom apartment
- Built-ins in both bedrooms, modern kitchen
- Minimal common walls, sunny balcony with views
- Internal laundry facilities and private car space
- Moments from transport, shops, cafes & all amenities

Price: SOLD Prior to AUCTION
Council Rates: \$255.00 p/q
Water Rates: \$162.00 p/q
Strata Rates: \$750.00 p/q

Frank Settineri

0414 889 319

Time Realty

9712 1188

12/93 Lyons Road, DRUMMOYNE

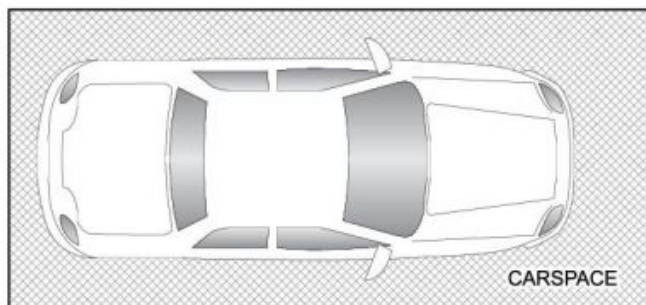
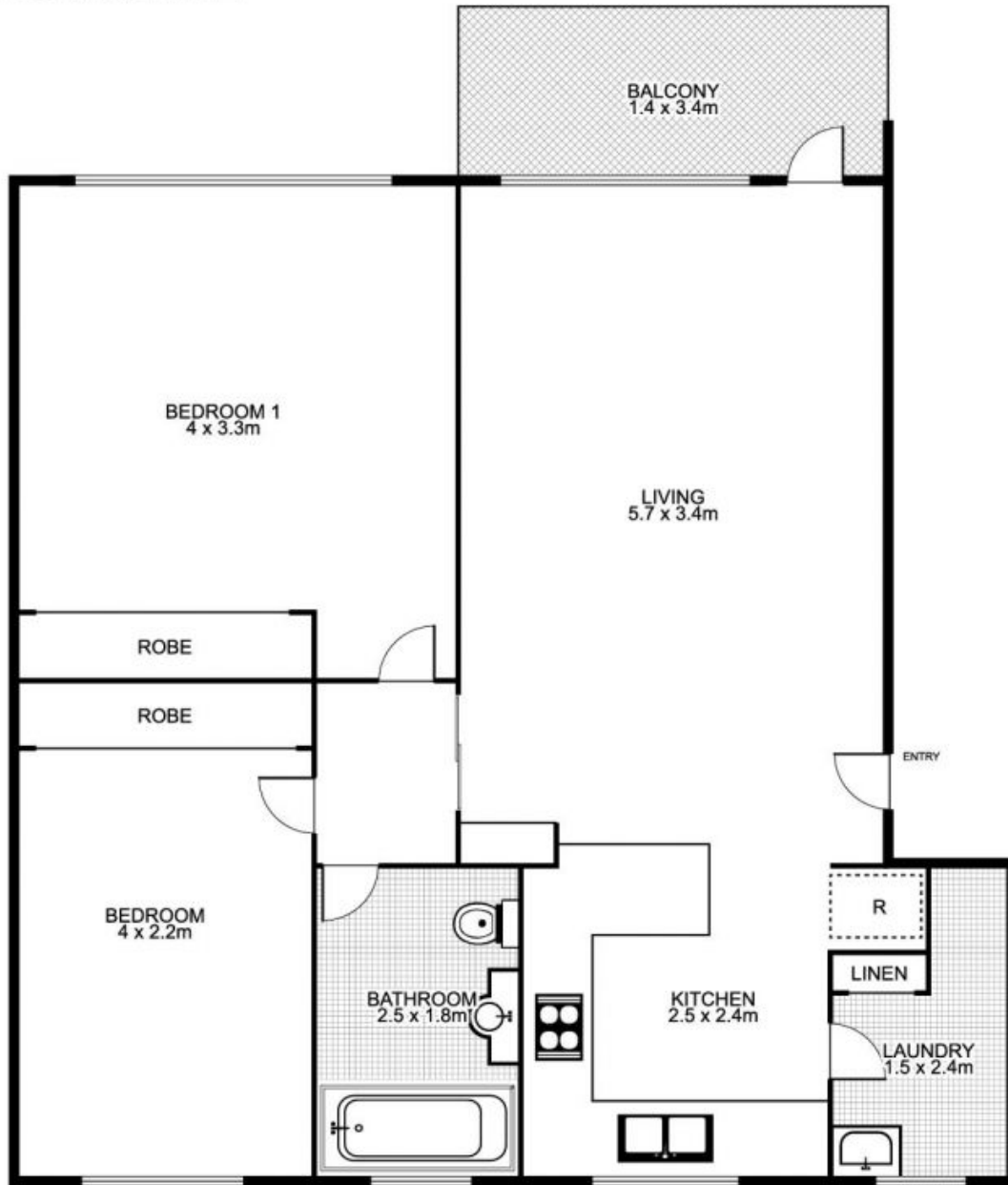

This floor plan is intended as a guide only. Layout dimension are approximate only. No representation or warranties of any nature whatsoever are given or intended. Any person using this information should rely on their own enquiries.