



98/21-23 Norton Street Leichhardt, NSW



2



2



1

SOLD - The Ultimate Lifestyle (Enter from Balmain Rd)

Enjoy Inner City living at its best with this stylish 2 bedroom apartment located in the iconic "Italian Forum". Offering open plan living area, 2 generously sized bedrooms with built-in wardrobes, 2 modern bathrooms including ensuite, quality kitchen with gas cooking, secure parking, internal laundry and balcony with stunning views over the Piazza. Live in the heart of the Inner Wests most vibrant cafe villages with almost everything at your doorstep while still only minutes from the CBD. This is the perfect opportunity for the either the first home buyer or astute investor.

Price: SOLD
Council Rates: \$282.00 p/q
Water Rates: \$186.00 p/q
Strata Rates: \$1,625.94 p/q

- Stylish 2 bedroom in the heart of Leichhardt
- Open plan living, 2 bathrooms, secure parking
- Internal laundry, balcony overlooking the Piazza
- Ideal first home or perfect for the astute investor
- Transport, shops, cafes & all amenities nearby

Frank Settineri

0414 889 319

Adam Scappatura

0413 355 481

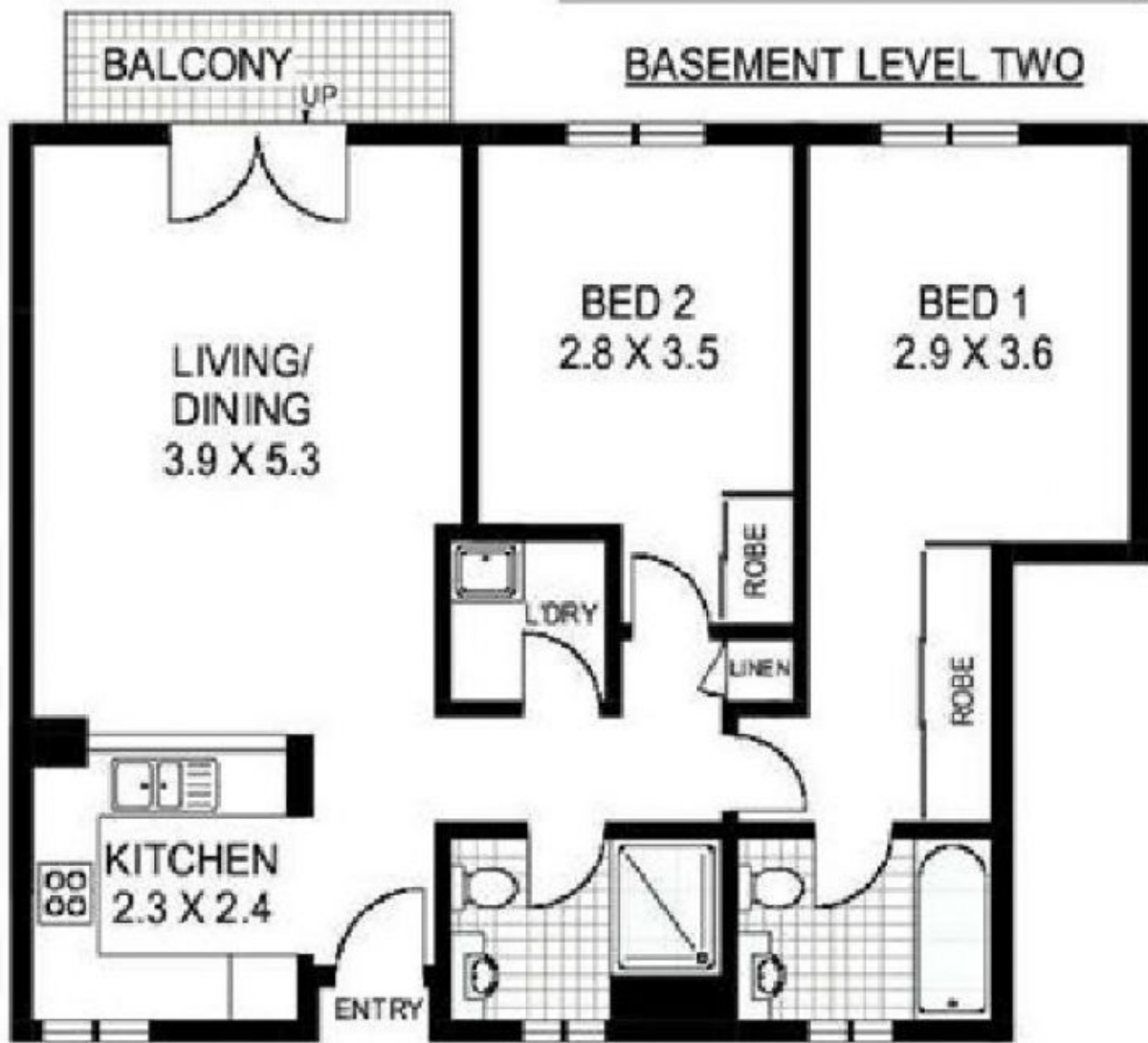
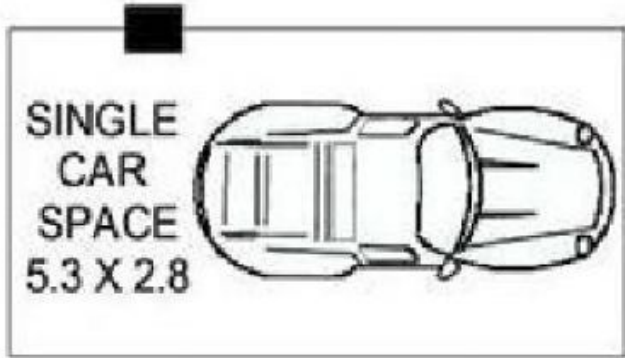

LEVEL TWO

98/21 - 23 NORTON STREET

LEICHHARDT

Plan Plan Disclaimer: Mind the Gap (ptg) floor plans / site plans are intended as guides only. No representations or warranties of any nature whatsoever are given or intended and any person using this information should always rely on their own enquiries. ptg property marketing services - 1300 133145 - photography - floor plans, virtual tours, video tours, copywriting, project marketing - www.mindthegap.com.au